

# PRESSURIZED OUTDOOR DOME - PFD8



Shown with optional WM20G wall mount

## DESCRIPTION

The FD8 outdoor 8" FusionDome™ offers versatility and camera protection in a compact size. It accepts unitized camera systems from Videolarm, Sensormatic/AD, Trinus, and Pelco, or a single fixed camera with a maximum camera length of 7.5" can be placed in the unit. A heater and blower are standard with the PFD8

## CERTIFICATIONS

- Tested to meet IP67
- Designed to meet NEMA 4X for water ingress
- Patent Pending

## ARCHITECTURAL/ENGINEERING SPECIFICATIONS

The PFD8 housing shall be an outdoor housing available in either wall or pendant mounted versions. The FusionDome™ shall be designed to accommodate unitized camera systems by manufacturers such as Sensormatic/AD, Pelco, and Trinus; and fixed cameras with a maximum camera length of 7.5". Adapter brackets for the unitized camera systems shall be included with each unit. Outdoor enclosures shall also be equipped with blowers and thermostatically controlled heaters shall also be included with the PFD8, allowing a temperature range of -50° F to +120° F. Units will be available with 24 VAC inputs. The housing shall be manufactured from a high-impact engineered plastic, UV protected, with a UL flame rating of 945VA. The dome shall be made of a thermoformed, optically clear, cell-cast acrylic material, and shall be held in place with (3) fasteners, and a sealing O-ring shall be included. A safety cable shall be provided to hold the dome while servicing. Access to the enclosure shall be from below.

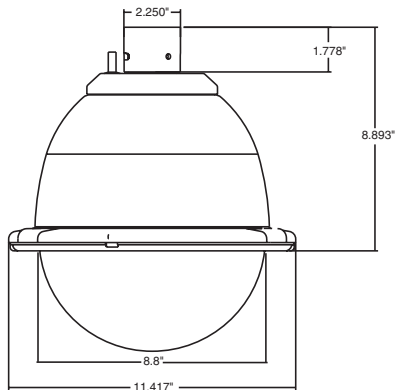

## ENVIRONMENTAL SPECIFICATIONS

Operating Temperature: -50° F to +120° F  
 Heater activates at +40° F (+/-8°), deactivates at +60° F (+/-5°)  
 Effective Projected Area (EPA): Approx. 180 square inches  
 Operating Humidity: Up to 100%

## LOW PRESSURE ALARM SPECIFICATIONS (PFD8C2A)

Switch Type: SPST Normally open  
 Current Rating 40mA resistive for life in excess of 20 million cycles  
 Operating Voltage AC/DC - 30V or less with resistive load  
 Pressure Set Point .43psi ( 29.8mbar)

## ELECTRICAL SPECIFICATIONS

24 VAC 52 watts (excluding camera)

## FEATURES

- Durable engineered plastic top, 945VA
- UV protected
- Accepts Videolarm or other manufacturer's unitized camera systems, or one fixed camera (7" MCL)
- Heater/blower standard
- Available as an S-View™ model with unitized pan/tilt/zoom camera and for Network Cameras

## MECHANICAL SPECIFICATIONS

Size (h x w x d): 13.5" x 11.5" x 11.5"  
 Weight: 10 lbs.  
 Construction:  
 Top: .125" engineered plastic  
 Dome: Cell-cast acrylic  
 Wall Mount Bracket: WM12 cast aluminum wall bracket standard.  
 Components:  
 Seals: .136" x 10.25" O-ring (FD8 and PFD8)  
 .136" x 4.5" O-ring (PFD8 only)  
 Pressure Relief Valve: 3 - 5psi  
 Schraeder Valve: Nitrogen input  
 Power Connectors (power/video/controls): 10-pin Souriau, hermetically sealed

## MODELS

**PFD8C2** - Pendant mount unit with clear lower dome, 24 VAC heater/blower/camera, and universal mounting plate for unitized camera systems  
**PFD8C2A** - Same as PFD8C2 except with fixed camera bracket  
**PFD8C2A** - Same as PFD8C2 except with Low Pressure Alarm

**NOTE:** Replace "C" with "T" in model number for tinted dome (1 F-stop light reduction)

## SHIPPING SPECIFICATIONS

| Model | Unit Weight | Shipping Weight | Shipping Box Dim. |
|-------|-------------|-----------------|-------------------|
| PFD8  | 7 lbs       | 7 lbs           | 17 x 14 x 17      |

\* Shipping weights depend on box dimensions.

6C

Pressurized Outdoor Dome