

2'X2' CEILING DOMES - OH081TL



DESCRIPTION

The OH081TL is a general purpose ceiling mount compact 8" dome for fixed cameras. The white body and dome are one piece integral construction, and this unit is designed to replace a 2' x 2' ceiling tile. The white body and compact 8" dome are one piece integral construction. The OH081TL is also available as a VideoKit™ model with hi-res color camera.

FEATURES

- Replaces a 2'x2' ceiling tile
- Cell-cast acrylic tinted dome
- Available clear or tinted (1 F stop light reduction)
- Low profile, dome extends only 4" below ceiling line
- One piece integral construction
- Adjustable camera bracket included
- MCL - 8"
- Also available as a VideoKit™ model with camera

ARCHITECTURAL/ENGINEERING SPECIFICATIONS

The ceiling mount dome housing shall be formed from cell-cast acrylic and be designed to replace a 2' x 2' ceiling tile. The dome shall be either clear or tinted, the tinted allowing 1 F stop light reduction, and shall be 8". The body shall be white. The unit shall feature one piece integral construction. An adjustable fixed camera bracket shall be included, and the maximum camera length shall be 8".

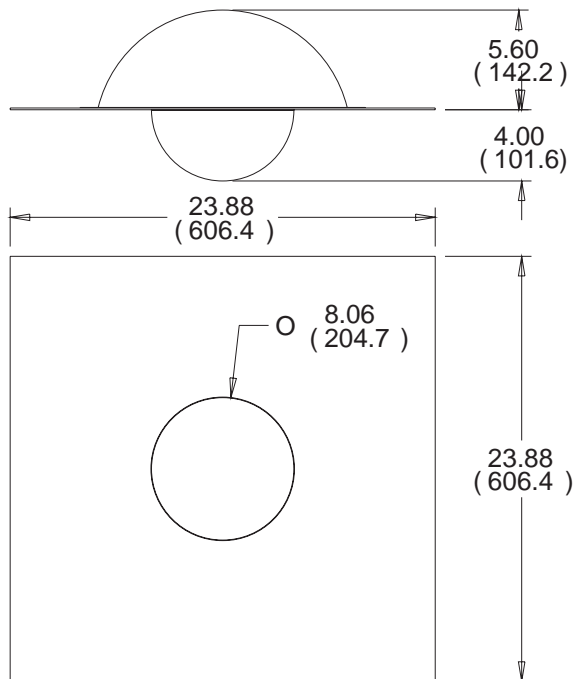

MODELS

- OH081TL** - Integral 12" diameter tinted dome with one fixed camera bracket, dust cover, and liner.
- OH081CL** - Integral 12" diameter clear dome with one fixed camera bracket, dust cover, and liner.

7E

Indoor 2' x 2'
Ceiling Domes

SHIPPING SPECIFICATIONS

Model	Unit Weight	Shipping Weight	Shipping Box Dim.
OH081TL	8 lb	8 Grd/8 Air*	25 x 26 x 7

* Shipping weights depend on box dimensions