

PENDANT MOUNT DOMES - FusionDome™ IFD8

DESCRIPTION

The IFD8 indoor FusionDome™ is a compact 8" pendant mount dome. It was engineered to accept a variety of manufacturers' unitized camera systems, including Sensormatic/AD, Trinus, and Pelco, or a single fixed camera with a maximum camera length of 7.5" can be placed in the unit. The pipe thread for the pendant mount version is 1" NPT.



FEATURES

- Durable engineered plastic top
- Standard pendant mount, wall mount available
- Accepts many manufacturer's unitized camera systems
- Accepts one fixed camera (7" MCL)
- Also available as an S-View™ model with unitized pan/tilt/zoom or a Q-View™ model with up to four cameras

CERTIFICATIONS

- Designed to meet NEMA 1 for falling dirt ingress
- Tested to meet IP66
- Patent Pending



ARCHITECTURAL/ENGINEERING SPECIFICATIONS

The IFD8 housing shall be an indoor housing available in either wall or pendant mounted versions. The FusionDome™ units shall be designed to accommodate unitized camera systems by manufacturers such as Sensormatic/AD, Pelco, and Trinus; and fixed cameras with a maximum camera length of 7.5". Adapter brackets for the unitized camera systems shall be included with each unit. The housings shall be manufactured from a high-impact engineered plastic. The dome shall be made of a thermoformed, optically clear, cell-cast acrylic material. The dome shall be held in place with (3) fasteners, and a sealing O-ring shall be included. A safety cable shall be provided to hold the dome while servicing the unit. Access to the enclosure shall be from below.

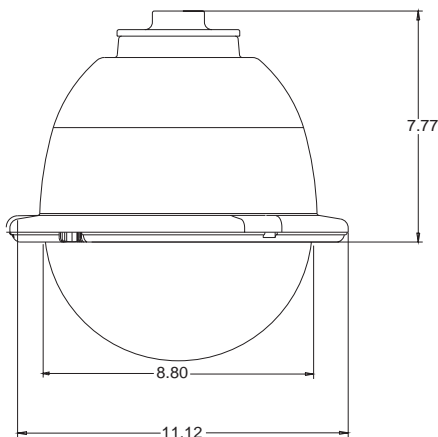

MODELS

IFDW8CF - Wall mount unit with clear lower dome, fixed camera bracket (MCL - 7.5")

IFDW8C - Wall mount unit with clear lower dome and universal mounting plate for unitized camera systems

NOTE: Replace "C" with "T" in model number for tinted dome (1 F-stop light reduction)

Replace "W" with "P" in model number for pendant mount

MECHANICAL SPECIFICATIONS

Size (h x w x d): 13.5" x 11.5" x 16.1"
Weight: 7 lbs.
Construction:
Top: .125" engineered plastic
Dome: Cell-cast acrylic

SHIPPING SPECIFICATIONS

Model	Unit Weight	Shipping Weight	Shipping Box Dim.
FD8	7 lbs	7 lbs	17 x 14 x 17

* Shipping weights depend on box dimensions.