



DESCRIPTION

The VideoKit™ ACN90-5A is a compact, aesthetically pleasing fixed camera system designed for indoor corner mount applications. Its low profile makes the ACN90-5A ideal for offices, hallways and conference rooms. Each unit features a hi-res color camera with 2.8mm fixed auto iris lens. Tamper resistant fasteners are also included.

FEATURES

- Hi-res color camera with 2.8mm fixed auto iris lens
- Attractive low-profile styling
- Injection molded, off-white polycarbonate plastic
- Convenient cable access slots
- Tamper resistant fasteners



CERTIFICATIONS

- Complies with Part 15 of the FCC Rules

ARCHITECTURAL/ENGINEERING SPECIFICATIONS

The ACN90-5A shall be constructed of off-white, injection-molded polycarbonate and shall be configured to allow corner mount installation. The viewing window shall be clear polycarbonate. The camera shall have a horizontal resolution of 460 TV lines, with a minimum illumination of 1.2 Lux in normal mode and 0.8 Lux in hi gain mode at F1.2. The front cover shall be hinged on the bottom to allow easy, hands-free access to the camera. It shall be secured by two tamper resistant fasteners

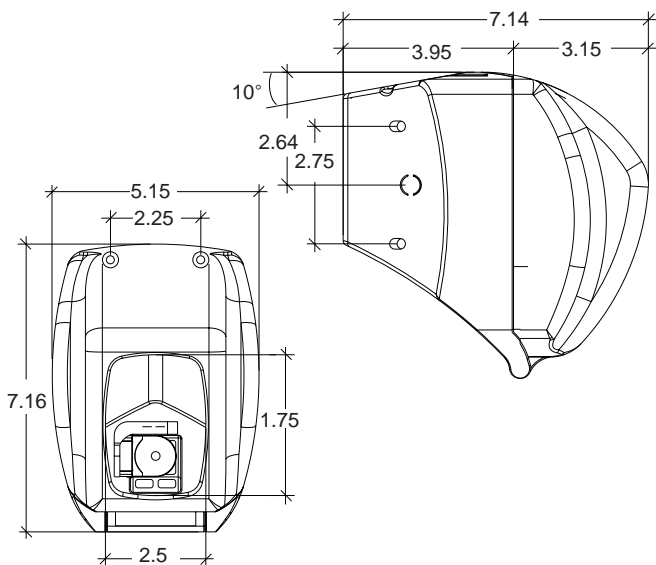

MODELS

ACN90-5A - Indoor corner mount fixed camera system with hi-res color camera, 2.8mm fixed auto iris lens, injection molded housing, 24 VAC input

ELECTRICAL SPECIFICATIONS

Power Input - 24 VAC

Power Consumption

Camera - 5 watts (208mA)

CAMERA SPECIFICATIONS - see page 40

SHIPPING SPECIFICATIONS

Model	Unit Weight	Shipping Weight	Shipping Box Dim.
ACN90-5A	1 lb	2 Grd/2 Air	12 x 10 x 7

* Shipping weights depend on box dimensions.

Product specifications are subject to change without notice.



CAMERA SPECIFICATIONS

- Power Input - 24 VAC
- Image Sensor - Interline 1/3" Sony Super HAD CCD
- Scanning System - 2:1 Interlaced
- Sync System - Internal/Linelock (Switchable)
- Horizontal Resolution - 460 TV Lines
- Signal to Noise Ratio - 48db or more (AGC off)
- Minimum Resolution (F1.2) - 1.2 Lux Normal Mode
0.8 Lux Hi Gain Mode
- Gain Control - Automatic
- Backlight Compensation - Center Zone Detection (on/off switchable)
- White Balance - Automatic/Hold (push lock)
- Dimensions - 1.9" (H) x 1.9" (W) x 3.3" (L)

Super HAD CCD is a registered trademark of Sony Corporation

LENS SPECIFICATIONS

2.8 - 12mm Lens

- Focal Length - 2.8 to 12mm
- Iris Range - F1.4 to 360
- Iris Operation - Auto Iris
- Focus Operation - Manual
- Diameter - 1.57"
- Length - 2.2"

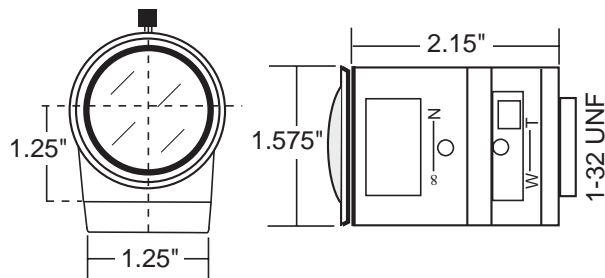

5 - 50mm Lens

- Focal Length - 5 to 50mm
- Iris Range - F1.4 to 185
- Iris Operation - Auto Iris
- Focus Operation - Manual
- Diameter - 1.7"
- Length - 2.3"

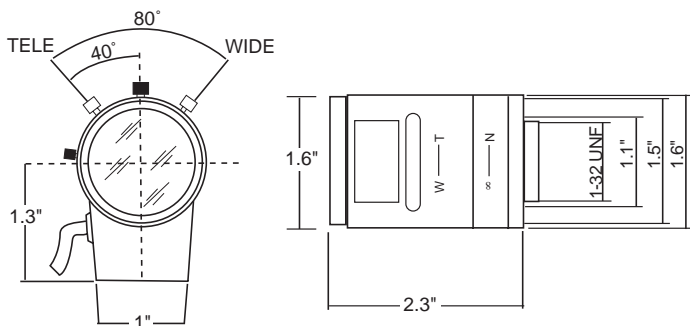

Neither the camera nor lens is available as a separately ordered item