

## DESCRIPTION

The ACN90 housing is designed for indoor corner mount situations. It has a low profile, which makes this attractively styled unit ideal for offices, hallways and conference rooms. The off-white, injection-molded polycarbonate indoor housing will accept a 6" maximum length camera. Each unit also features tamper resistant fasteners.



## FEATURES

- Attractive low-profile styling
- Injection molded, off-white polycarbonate plastic
- Comes with completely adjustable camera bracket
- Convenient cable access slots
- Tamper resistant fasteners
- Right-angle BNC connector is included to accommodate maximum camera lengths
- Also available as a VideoKit™ model with camera

## ARCHITECTURAL/ENGINEERING SPECIFICATIONS

The ACN90 indoor housing shall be constructed of off-white, injection-molded polycarbonate and shall be intended for indoor use only. The ACN90 shall be capable of housing a 6" maximum length camera with tilt angles ranging from 5° - 55°. The camera will attach to the camera mount with one 1/4-20 screw and rubber pad. The housing shall come complete with tamper-resistant fasteners and convenient cable access slots.

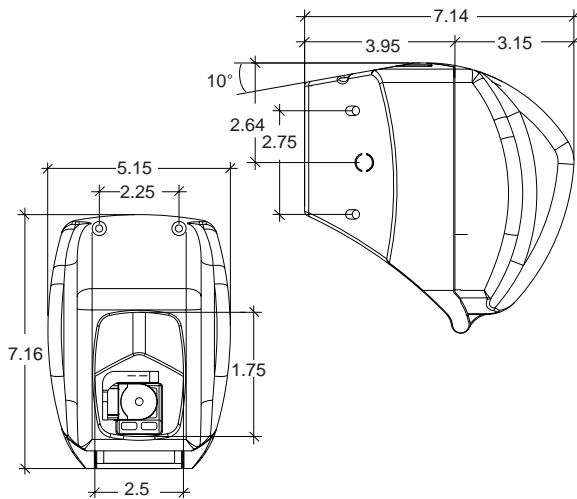

## MODELS

**ACN90C** - High impact plastic housing with clear viewing window, tamper-resistant fasteners, and camera mount with 5° - 55° tilt capabilities.

## SHIPPING SPECIFICATIONS

Model	Unit Weight	Shipping Weight	Shipping Box Dim.
ACN90	1 lb	2 Grd/2 Air	12 x 10 x 7

\* Shipping weights depend on box dimensions.