

CAMERA/HOUSING PACKAGES - VideoKit™ ACH8-5A Outdoor Housing



DESCRIPTION

The VideoKit™ ACH8-5A is an aluminum outdoor housing designed to give years of service in a variety of applications. Each unit includes a hi-res color camera with 5mm-50mm auto iris lens, and a metal wall mount. Access to the camera is easy with the side hinged top. The body is an attractive white finish with black end caps. A heater/blower and sunshield are available.

FEATURES

- Hi-res color camera with 5mm-50mm auto iris lens
- Side hinge for easy access when servicing
- Aluminum body, metal wall mount included
- Side hinged for easy access
- Optional 24 VAC heater/blower and sunshield



CERTIFICATIONS

- Complies with Part 15 of the FCC Rules

ARCHITECTURAL/ENGINEERING SPECIFICATIONS

The VideoKit™ ACH8-5A environmental housing shall be constructed from two extruded aluminum (.08" wall thickness, white finish) halves and two injection-molded polycarbonate end caps. A clear polycarbonate viewing window shall be ultrasonically welded to the inside of the front end cap, creating a watertight seal. The rear end cap shall have molded standoffs on the inside surface for easy mounting of the optional blower. The top of the housing shall be hinged from the side to allow accessibility to the camera by removal of one screw from each end cap. Access to the camera for adjustment or removal shall be provided via one screw located in the key hole slot on the aluminum camera sled. An optional 25 vA heater may be mounted to the inside of the bottom extrusion, directly behind the viewing window, for defogging and deicing. Four vent plugs (2 in front, 2 in rear) will create a positive air flow (front to rear) when the blower is in use. Two watertight strain relief plugs will be located at the rear of the housing for separate coax and power cable entry. A fixed hi-res color camera shall be included, and shall feature an auto iris 5mm-50mm lens. The camera shall have a horizontal resolution of 460 TV lines, with a minimum illumination of 1.2 Lux in normal mode and 0.8 Lux in hi gain mode at F1.2. Optional extruded aluminum sunshield and a red flashing light kit shall also be available as separate boxed items.

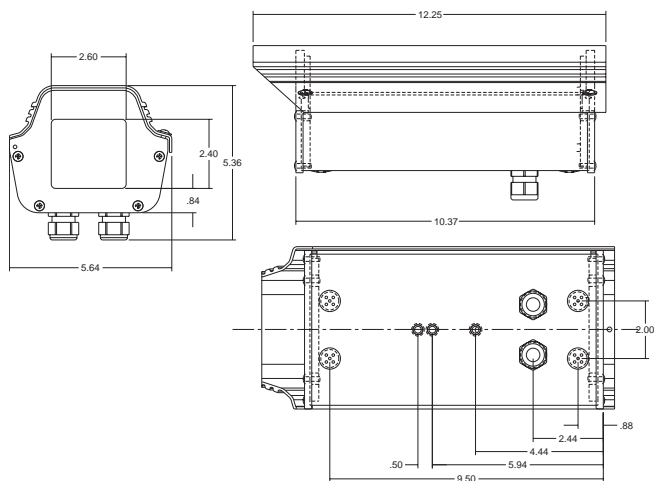

MODELS

ACH8-5A - Outdoor fixed camera system with hi-res color camera, 5-50mm auto iris lens, and metal wall mount,

ACH8HB-5A - ACH8-5A with factory installed 24 VAC heater/blower/thermostat

OPTIONS/ACCESSORIES

AC10 - Tamper-resistant screw set

ACH2 - 24 VAC heater/thermostat kit

ACB2 - 24 VAC blower/thermostat kit

ACHY8 - Sunshield for ACH8 models

CM800 - Corner Mount bracket

CA1200 - Ceiling Mount bracket

ELECTRICAL SPECIFICATIONS

Power Source

ACH13HB - 24 VAC, 50/60 Hz

Heater - 24 VAC, 25 vA, 1.04 Amps

Blower - 24 VAC, input (RECTIFIED), 1.4 vA

CAMERA SPECIFICATIONS - see page 40

SHIPPING SPECIFICATIONS

Model	Unit Weight	Shipping Weight	Shipping Box Dim.
ACH8-5A	4 lbs (1.9 kg)	4 Grd/4 Air	17 x 5 x 6

* Shipping weights depend on box dimensions.



CAMERA SPECIFICATIONS

- Power Input - 24 VAC
- Image Sensor - Interline 1/3" Sony Super HAD CCD
- Scanning System - 2:1 Interlaced
- Sync System - Internal/Linelock (Switchable)
- Horizontal Resolution - 460 TV Lines
- Signal to Noise Ratio - 48db or more (AGC off)
- Minimum Resolution (F1.2) - 1.2 Lux Normal Mode
0.8 Lux Hi Gain Mode
- Gain Control - Automatic
- Backlight Compensation - Center Zone Detection (on/off switchable)
- White Balance - Automatic/Hold (push lock)
- Dimensions - 1.9" (H) x 1.9" (W) x 3.3" (L)

Super HAD CCD is a registered trademark of Sony Corporation

LENS SPECIFICATIONS

2.8 - 12mm Lens

- Focal Length - 2.8 to 12mm
- Iris Range - F1.4 to 360
- Iris Operation - Auto Iris
- Focus Operation - Manual
- Diameter - 1.57"
- Length - 2.2"

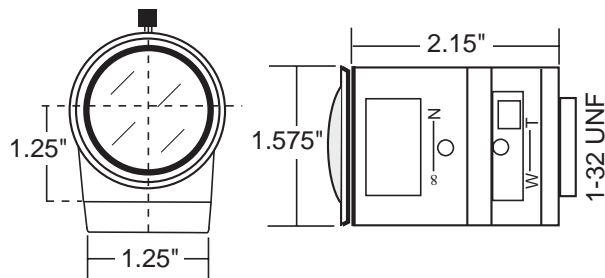

5 - 50mm Lens

- Focal Length - 5 to 50mm
- Iris Range - F1.4 to 185
- Iris Operation - Auto Iris
- Focus Operation - Manual
- Diameter - 1.7"
- Length - 2.3"

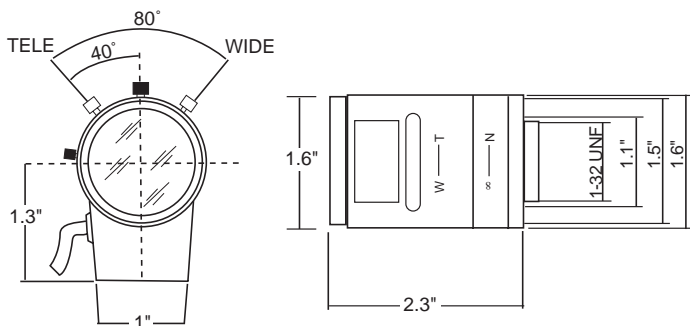

Neither the camera nor lens is available as a separately ordered item