



## DESCRIPTION

A low-profile surface mount unit, the **VideoKit™ ACE20-5A** is an attractive addition to indoor surveillance systems. Its sleek and attractive lines make allow it to fit into a variety of indoor applications such as offices, hospitals, schools, and many more. Each ACE20-5A includes a hi-res color camera with 2.8-12mm auto iris lens. The ACE20 is easy to install, and the molded-in hinge makes camera access easy as well. Tamper-resistant fasteners are included to protect the camera equipment from vandals.

## FEATURES

- Hi-res color camera, 2.8-12mm auto iris lens
- Off-white, high-impact polycarbonate housing and window
- Easy installation to any type of ceiling
- Tamper-resistant fasteners
- Molded-in hinge to allow easy access from below



## CERTIFICATIONS

- Complies with Part 15 of the FCC Rules

## ARCHITECTURAL/ENGINEERING SPECIFICATIONS

The ACE20-5A shall be constructed from high-impact off-white polycarbonate, and shall contain a clear polycarbonate viewing window. The base plate shall be polycarbonate, and shall contain three conduit knockouts on the bottom section for cable and wiring entry. The housing cover shall be attached to the base plate, and secured with two tamper-resistant fasteners. A fixed hi-res color camera with 2.8-12mm auto iris lens shall be included. The camera shall have a horizontal resolution of 460 TV lines, with a minimum illumination of 1.2 Lux in normal mode and 0.8 Lux in hi gain mode at F1.2.

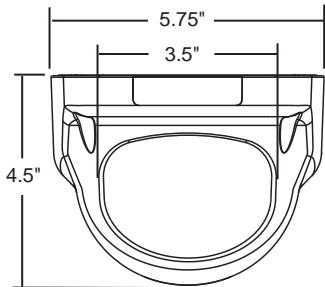
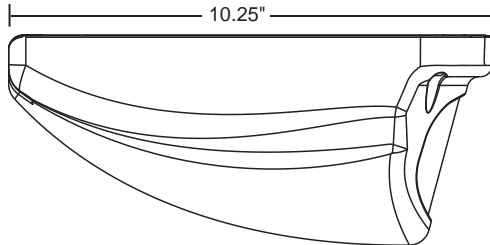

## MODELS

**ACE20-5A** - Indoor ceiling mount wedge fixed camera system with hi-res color camera, 2.8-12mm auto iris lens, injection molded housing, 24 VAC input

## ELECTRICAL SPECIFICATIONS

**Power Input** - 24 VAC

**Power Consumption**

Camera - 5 watts (208mA)

## CAMERA SPECIFICATIONS - see page 40

## SHIPPING SPECIFICATIONS

Model	Unit Weight	Shipping Weight	Shipping Box Dim.
ACE20-5A	1 lb	2 lbs	13.5 x 8 x 6

\* Shipping weights depend on box dimensions.



## CAMERA SPECIFICATIONS

- Power Input - 24 VAC
- Image Sensor - Interline 1/3" Sony Super HAD CCD
- Scanning System - 2:1 Interlaced
- Sync System - Internal/Linelock (Switchable)
- Horizontal Resolution - 460 TV Lines
- Signal to Noise Ratio - 48db or more (AGC off)
- Minimum Resolution (F1.2) - 1.2 Lux Normal Mode  
0.8 Lux Hi Gain Mode
- Gain Control - Automatic
- Backlight Compensation - Center Zone Detection (on/off switchable)
- White Balance - Automatic/Hold (push lock)
- Dimensions - 1.9" (H) x 1.9" (W) x 3.3" (L)

*Super HAD CCD is a registered trademark of Sony Corporation*

## LENS SPECIFICATIONS

### 2.8 - 12mm Lens

- Focal Length - 2.8 to 12mm
- Iris Range - F1.4 to 360
- Iris Operation - Auto Iris
- Focus Operation - Manual
- Diameter - 1.57"
- Length - 2.2"

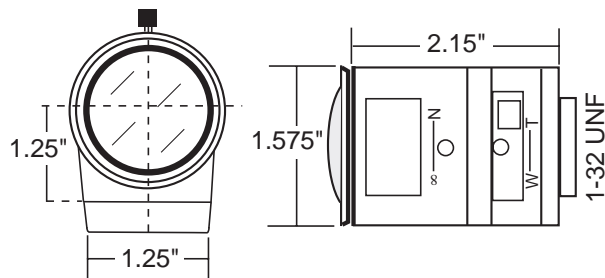

### 5 - 50mm Lens

- Focal Length - 5 to 50mm
- Iris Range - F1.4 to 185
- Iris Operation - Auto Iris
- Focus Operation - Manual
- Diameter - 1.7"
- Length - 2.3"

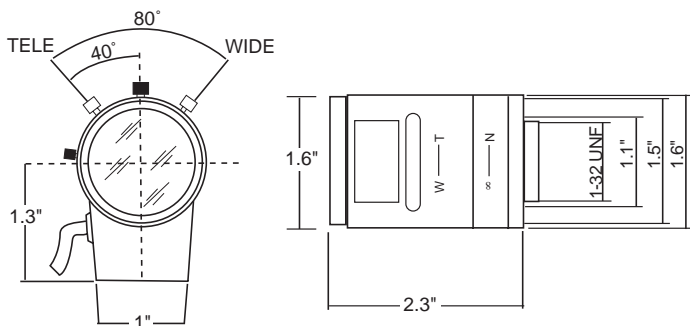

*Neither the camera nor lens is available as a separately ordered item*